

LA-7354-MS

Informal Report

Special Distribution

Issued: July 1978

3

UNCLASSIFIED

PUBLICLY RELEASABLE

Per E. M. Sandoval, FSS-16 Date: 5-6-92

By Marlene Lujan, CIC-14 Date: 8-16-95

Conical Shaped Charge Liner

Fabrication Development (U)

James F. Muller  
Edmund L. Van De Valde  
James M. Dickinson  
Donald J. Sandstrom

CIC-14 REPORT COLLECTION  
REPRODUCTION  
COPY

LOS ALAMOS NATIONAL LABORATORY



3 9338 00371 7864



UNCLASSIFIED

University of California

LOS ALAMOS SCIENTIFIC LABORATORY

Post Office Box 1663 Los Alamos, New Mexico 87545

Classified by E. M. Sandoval  
ISD-6 Classification Analyst

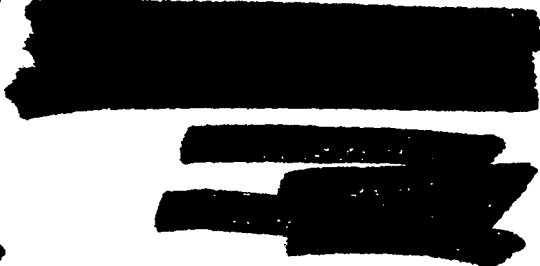

  
An Affirmative Action/Equal Opportunity Employer

UNCLASSIFIED

This work was supported by the US Army Ballistics  
Research Laboratory.

  
This report was prepared as an account of work sponsored  
by the United States Government. Neither the United States  
nor the United States Department of Energy, nor any of their  
employees, nor any of their contractors, subcontractors, or  
their employees, makes any warranty, express or implied, or  
assumes any legal liability or responsibility for the accuracy,  
completeness, or usefulness of any information, apparatus,  
product, or process disclosed, or represents that its use would  
not infringe privately owned rights.

UNITED STATES  
DEPARTMENT OF ENERGY  
CONTRACT W-7408-ENG. 36

UNCLASSIFIED

UNCLASSIFIED

**THE FABRICATION OF CONICAL TANTALUM SHAPED CHARGED LINERS**  
**FINAL REPORT**

by

**James F. Muller, Edmund L. Van De Valde,  
James M. Dickinson, and Donald J. Sandstrom****ABSTRACT**

Truncated tantalum cones were fabricated for use by the US Army Ballistics Research Laboratory as metal liners for experimental shaped charge armor penetrating devices. Tantalum was chosen for use in these devices because of its excellent properties. The cones were fabricated at ambient temperature using a multistep forming sequence. Design of the necessary tooling was accomplished using an analytical approach, which included surface area and volumetric shift calculations. The tantalum plate used to fabricate the cones was initially cross rolled at least 25% before forming. This procedure was performed to minimize the formation of large grains because of critical strain effects resulting from the final vacuum annealing operation, which was done before machining. Metallographic studies were performed on selectively annealed material samples that had been similarly rolled. These studies were used to determine the best annealing treatment for the actual parts. Metallography was also done on one of the conical liners subsequent to final fabrication and annealing.

LOS ALAMOS NATL LAB LIBS



3 9338 00371 7864

**I. INTRODUCTION**

Late in 1975, representatives of the US Army Ballistics Research Laboratory (BRL) visited the Los Alamos Scientific Laboratory (LASL) to discuss programs of mutual interest in shaped charge munitions development. The BRL had conducted a research program in which they had employed high-density metals such as uranium alloys as liners for conventional conical shaped charges. The effectiveness of liners fabricated from uranium-6 wt% niobium alloy was subjectively described as outstanding.

The Materials Technology Group (CMB-6) of LASL has had a considerable amount of experience in fabricating and developing a variety of shaped charge liners and liner materials and was asked what material (other than uranium or one of its alloys) would be optimum for a shaped charge liner application. We believe that physical/mechanical properties such as high density, high-spall strength, high-melting point, and good dynamic elongation at high-strain

UNCLASSIFIED

rates are important characteristics of a liner material. At LASL, a wide variety of materials have been studied to determine their Hugoniot Elastic Limits (HEL) and spall strengths. Table I is a compilation of some HEL and spall strength data for some selected materials. Tantalum and tantalum-10 wt% tungsten alloy (Ta-10W) possessed the best combination of density and spall strength. In addition, these two materials have high-melting points and are not likely to be easily shock-melted in the intended application. We also have had experience at LASL with the dynamic deformation of these two materials and observed that they would undergo massive amounts of stretching before failure. One final advantageous property of tantalum and Ta-10W is that they do not undergo any phase transformations when subjected to shock loading, which has been known to absorb considerable amounts of energy and could reduce the total energy delivered into the formed jet.

Tantalum and Ta-10W appeared to be obvious choices as optimum liner materials and their use was suggested to BRL. In collaboration with BRL, a work statement (see Appendix A) was prepared that outlined a cooperative program for the evaluation of these materials as liners. Funding was provided and BRL designed the conical liner configuration to be used in this evaluation (Fig. 1). During our initial preparation to fabricate these liners, BRL expressed a need for conical liners other than the original design. Figure 2 shows the three liner configurations

TABLE I

## HUGONIOT ELASTIC LIMIT AND SPALL STRENGTHS OF SELECTED MATERIALS

Sample No.	Material	Density g/cm <sup>3</sup>	Long. Sound Velocity (mm/μsec)	Shear Wave Velocity (mm/μsec)	Hugoniot-Elastic Limit (K bars)	Spall Strengths (K bars)
1	A-286 Stainless Steel (age hardened 715°C/16h)	7.96	5.70	3.14	13.6	33
2	21-6-9 Stainless Steel (annealed)	7.81	5.72	3.15 oriented 3.12	11.4	32
3	304L Stainless Steel (annealed)	7.89	5.77	3.12	12	---
4	Almar 362 (aged at 1100°F/8h)	7.76	5.91	3.22	17	21
5	HP-9-4-20C (aged at 1050°F)	7.92	5.79	3.22	15	28
6	250 Maraging Steel	8.13	5.53	2.97	27	60
7	300 Maraging Steel	8.03	5.57	3.01	27	42
8	Tungsten (cast and worked)	19.24	5.18	2.85	48	18
9	Ta-10 wt% W (annealed)	16.93	4.20	2.10 oriented 2.13	32	64
10	Tantalum (annealed)	16.69	4.16	2.09	15	43
11	Cu-1:8 wt% Be (aged at 400°C/4h)	8.33	4.9	2.49 oriented 2.43	13	19
12	Titanium (annealed)	4.52	6.01	3.08 oriented 3.04	15	31

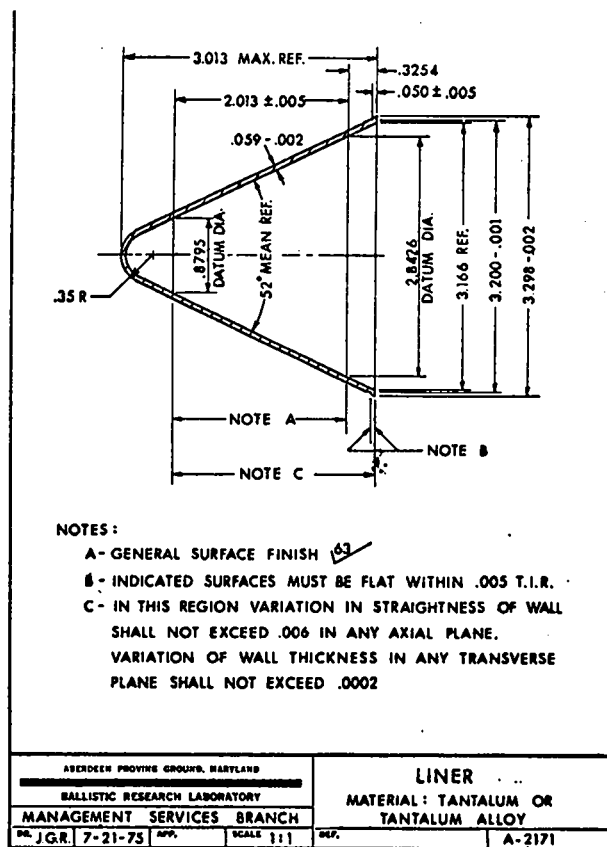

Fig. 1.  
Original liner configuration designed by BRL  
(all dimensions are in inches).

specified. The basic outer contour of all three is the same; they differ from one another only in wall thickness, reflected in the inner contour dimensions and overall length as well. We were requested to supply 21 of these truncated conical liners, 7 each of the three wall thickness configurations. All 21 liners were to be made from pure tantalum.

Because of the urgency of the BRL request, a change in the program was instituted. BRL additionally needed one of these liners (in configuration 5) as soon as possible. We suggested fabricating a cone using a roll forming and welding procedure. This suggestion was accepted and a welded liner was fabricated from material supplied by BRL. BRL had purchased a quantity of annealed 9.53 and 6.35-mm-thick tantalum plate for use in this program. All the furnished plate was from one heat of material (Table II). Concurrent with the fabrication of the welded liner, the design of tooling for making monolithic conical liners was undertaken.

## II. FABRICATION PROCEDURES

### A. Roll Formed and Welded Conical Liner

A number of steps were required to fabricate this one liner; the tooling requirements, however, were minimal. A portion of the supplied 9.53-mm-thick tantalum plate was rolled approximately

UNCLASSIFIED

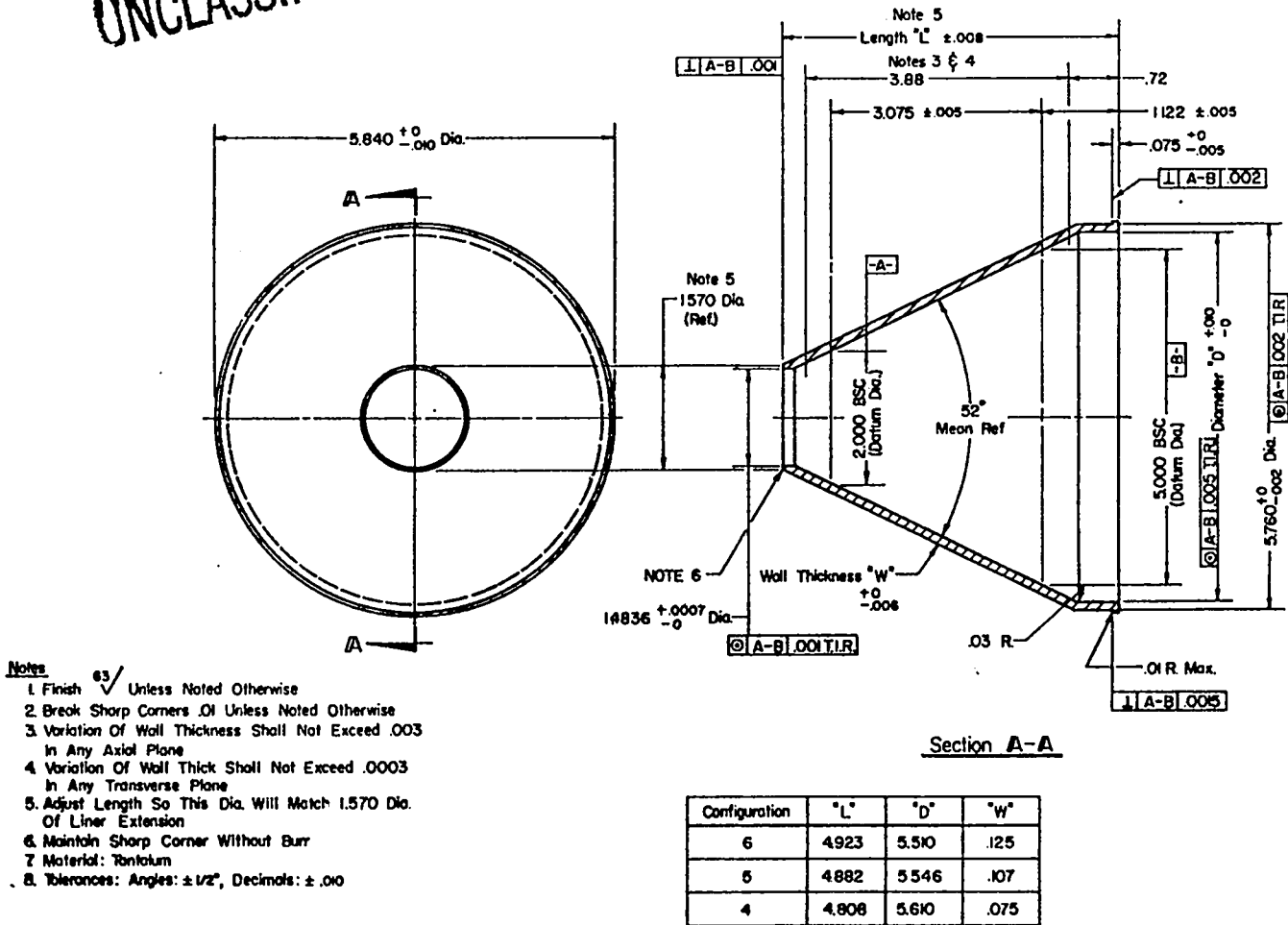

Fig. 2. Truncated liner configurations designed by BRL (all dimensions are in inches).

50% at ambient temperature and machined into developed sections. Each section was approximately that for two-thirds of the required conical shape. This included the area for two mandrel attachment holes used during roll forming, which was later machined off. These sections were vacuum annealed for 30 min at 1200°C. The 50% cold rolling and annealing procedure was performed before roll forming to reduce possible critical strain effects in the material. These effects could have ultimately resulted in an undesirably large grain size in the cone. BRL had requested that all the conical liners possess a relatively uniform fine recrystallized grain size. It would have been preferable to have roll formed the sections in the as-rolled condition before annealing. However, this was not possible with tantalum of this thickness in so highly a strain hardened condition with our existing equipment. Therefore, after annealing, the sections were roll formed into the desired shape (Fig. 3). The roll forming operation was done at room temperature using a steel mandrel mounted in an ordinary lathe.

The roll-formed conical sections had their hole attachment areas machined off and step joints were machined into their slant faces to facilitate electron beam (EB) welding; the joints were located 180° apart. After welding, the cone was coined in a die to more fully define the conical contour itself and to produce the cylindrical straight section extending from the cone base. The

UNCLASSIFIED

~~CONFIDENTIAL~~ UNCLASSIFIED

TABLE II

CHEMICAL ANALYSIS OF BRL  
FURNISHED TANTALUM PLATE

Element	Amount Present (ppm)
Ta	Bal.
C	<10
O	43
N	11
H	<5
W	80
Cb	350
Zr	<10
Mo	<10
Ti	<10
Fe	<10
Ni	<10
Si	<10
Mn	<10
Ca	<10
Al	<10
Cu	<10
Sn	<10
Cr	<10
V	<10
Co	<10
Mg	<10
Na	<10



Fig. 3.  
Roll formed tantalum conical section.

small lip at the end of the cylindrical section was added by EB welding a tantalum ring onto the end of the coined piece. The end of the cylindrical section of the part had been machined to accommodate a scarf joint configuration consistent with that of the ring. Subsequent to the welding operations, the cone was radiographed and found to be free of defects. The welded cone then received a vacuum stress relief of 900°C for 30 min; this was necessary to relieve the residual roll forming and welding stresses. This specific treatment was chosen to prevent an alteration of the grain size produced by the previous cold rolling and annealing procedures. The stress relieved cone was then finish machined. After machining, the weld zones, although difficult to find, were located so that BRL could fire the liner with these welds situated in a predetermined plane.

BRL fired the liner using a long stand-off so that the formed jet could be examined. The analysis of the jet indicated no major perturbations attributable to the welds, although some bending of the jet was observed at approximately 90° to these joints. This is certainly an indication that weld joints and other material variations may not be as detrimental to jet formation as had been thought. The performance of this liner was rated as being quite good by BRL.

UNCLASSIFIED

UNCLASSIFIED

**B. Monolithic Conical Liners**

A set of multistep drawing tools was designed for the fabrication of monolithic, truncated conical liners (see Appendix B). This set of tooling was designed to form 4.76-mm-thick sheet into the necessary shape from which the two thinner liner configurations could be machined. A separate set of tools was planned for the fabrication of the thickest liner configuration, we felt that the probability of machining these thickest liners from 4.76-mm-thick formed cones would not be very good. Inspection of some of the first cones formed indicated that we could machine all three liner configurations from cones formed using only the one set of tools.

All stages in the forming sequence were performed in a hydraulic press except the first stage, which was a hydroforming operation. We used some 4.76-mm-thick mild steel blanks as prototypes for initial forming trials. Once these were successfully formed, we proceeded to fabricate the first tantalum cone. We initially copper plated the first blank in an effort to prevent galling from occurring during the forming sequence. This copper plate adhered poorly, however, and broke off during the hydroforming operation. Bishop Lube (Jaytolube) precoat was successfully used as the lubricant for the rest of the forming sequence for the first tantalum cone and for all the operations on the remaining cones.

The cones were fabricated at ambient temperature using the sequence of forming operations compiled in Table III. Figures 4-5 show several of the tools used. Figure 6 shows one of the cones after all forming was complete.

The first six tantalum cones were fabricated from 4.76-mm-thick sheet that we had cross rolled at room temperature from the 9.53-mm-thick plate purchased for us by BRL; this represented a 50% cold reduction. Our supply of this 9.53-mm-thick plate was exhausted after the fabrication of the first six cones. The remaining cones were fabricated from 6.35-mm-thick tantalum plate, supplied by BRL, which we cross rolled 25%. This was the only material available at the time to complete the program.

TABLE III

**SEQUENCE OF FORMING OPERATIONS FOR THE FABRICATION  
OF TRUNCATED CONICAL TANTALUM SHAPED CHARGE LINERS**

1. Machine a 248-mm-diam circular blank from cross rolled (25% or 50%) 4.76-mm-thick tantalum sheet.
2. Coat both surfaces of the blank with Bishop Lube precoat and allow to dry for approximately 45 minutes.
3. Hydroform using the first stage punch.
4. Machine off the uneven areas around the flange of hydroformed part.
5. "Wipe-off" the flange using the first stage punch and a draw ring. This "wiping" operation removes the flange by drawing it in against the punch.
- 6 thru 9. Draw cone using four sets of punches and matched dies (Stages 2-5).
10. Relubricate as in Step 2.
11. Draw the next segment of the cone using the Stage 6 punch and die.
12. "Rewipe" the cylindrical section using the draw ring from Step 5 and the Stage 6 punch. This is done to restraighen this area of the part before the coining operation.
13. Machine the edge of the cylindrical section. This is also done to facilitate the coining operation.
14. Coin the formed part using the Stage 7 punch and female coining die.

UNCLASSIFIED



~~CONFIDENTIAL~~

UNCLASSIFIED



Los Alamos Scientific Laboratory  
OF THE UNIVERSITY OF CALIFORNIA

Fig. 4.

*Punches from the seven stages of cone forming tools.*

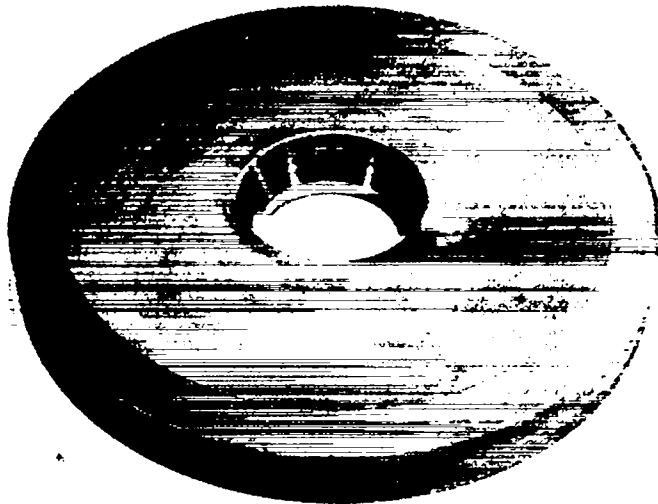

Los Alamos Scientific Laboratory  
OF THE UNIVERSITY OF CALIFORNIA

Fig. 5.

*Typical cone forming die from one of the intermediate stages.*

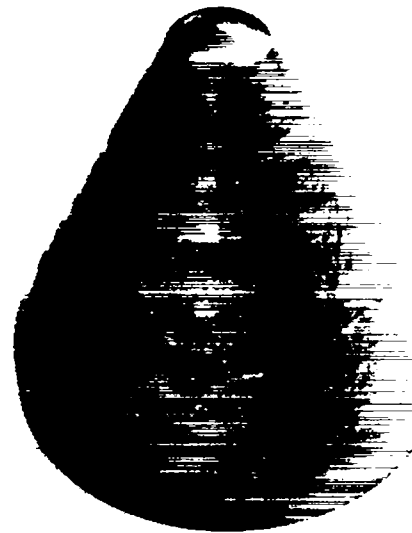

Los Alamos Scientific Laboratory  
OF THE UNIVERSITY OF CALIFORNIA

Fig. 6.

*Finish formed tantalum cone.*

UNCLASSIFIED

50% rolled material were annealed at 1200°C for 30 min; those fabricated from the 25% rolled material were annealed at 1300°C for 30 min. The temperatures and times of these anneals were selected on the basis of a recrystallization and grain growth study that had been conducted on these materials (see following section). A dimensional inspection of one of the cones before and after annealing revealed that no distortion resulted from the heat treatment.

The 21 liners were machined to tolerance from the fabricated and annealed cones. Unfortunately, 14 of these liners instead of 7 were machined into the thickest walled configuration. However, BRL accepted all of the liners as machined and were able to modify their shots to accommodate the actual numbers of each configuration supplied.

### III. METALLURGICAL EVALUATION AND CONTROLS

Recrystallized tantalum metal has a very strong tendency to form duplex structures, i.e., to have grains of widely different grain size often in colonies within the same slab or billet. Figure 7 shows such a structure; the microstructure shown is that of the 6.35-mm-thick tantalum plate used to make a number of the conical liners. Practically, it is quite difficult to prevent a tendency toward this type of structure because it is related to the prior strain in the individual grains, the direction of the strain and the orientation of the grains.

We chose to work the tantalum plate available for this program as heavily as possible as the best means of providing uniformity in the final shapes. The accepted value of critical strain for polycrystalline tantalum is 18%; this critical strain is that minimum value of deformation necessary to cause recrystallization to occur during subsequent annealing. For tantalum, which has been strain hardened an amount greater than 18% and annealed, the recrystallized grain size tends to become finer and more uniform with increasing amounts of this prior strain.

The maximum amount of deformation applied to the material used in this program was controlled by the minimum thickness of plate necessary for the forming operations, 4.76 mm. The 9.53-mm-thick plate, therefore, received a 50% reduction by rolling whereas the 6.35-mm-thick plate was reduced only 25%. We attempted to reduce the 9.53-mm-thick plate by cross rolling in two equal passes. Our heaviest rolling mill was used but the required thickness per pass was not achieved and a "light" pass in each direction was required to reach the 4.76-mm thickness. The light rolling passes resulted in a nonuniform deformation pattern that ultimately manifested itself as a banded grain structure after final annealing. This occurred because the light passes tended to work the surfaces of the plate more than the interior of the material. Fig. 8 shows the microstructure of the 9.53-mm-thick plate as received (note the relatively uniform grain size and microstructure). Fig. 9 shows the microstructure of the test sample of this same material that received a vacuum annealing treatment of 1200°C/30 min after rolling. This sample showed a considerable amount of banding as a result of the rolling schedule. However, this sample was judged to possess as fine a recrystallized grain structure as might be expected, given the undesirable rolling schedule, and it did possess an annealed hardness of DPH 75-78. It should be additionally pointed out that had the cones been fabricated from this sheet directly (without any prior cold rolling) the grain size variation throughout would have most certainly been more severe.

This sample was one of several as-rolled specimens that was subjected to various annealing treatments as part of a recrystallization and grain growth study. The purpose of this study was to aid us in specifying the best annealing procedure for the fabricated cones. Naturally, the formed cones had a small additional amount of strain hardening because of the forming sequence; however, the as-rolled samples were adequate for determining satisfactory annealing treatments.



*Fig. 7.*  
Microstructure of 6.35-mm-thick tantalum plate as received from the mill. Note the heavily banded and duplex grain structure.

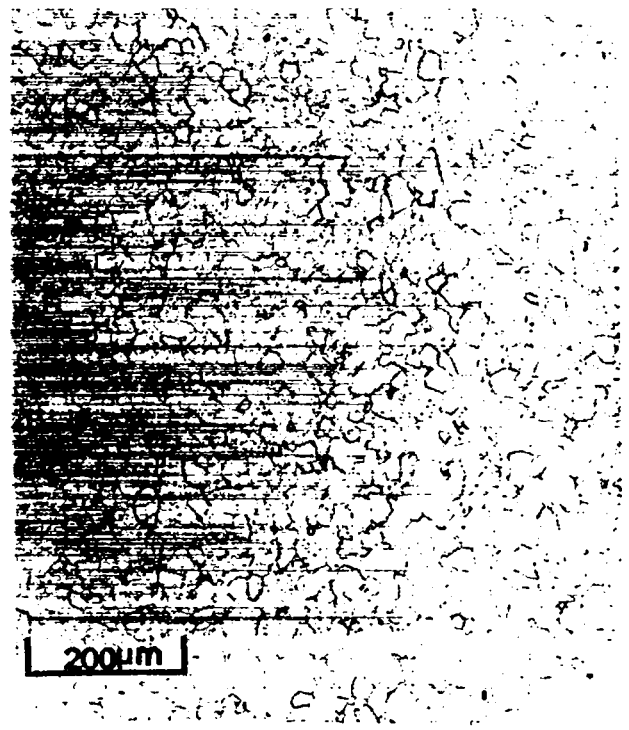
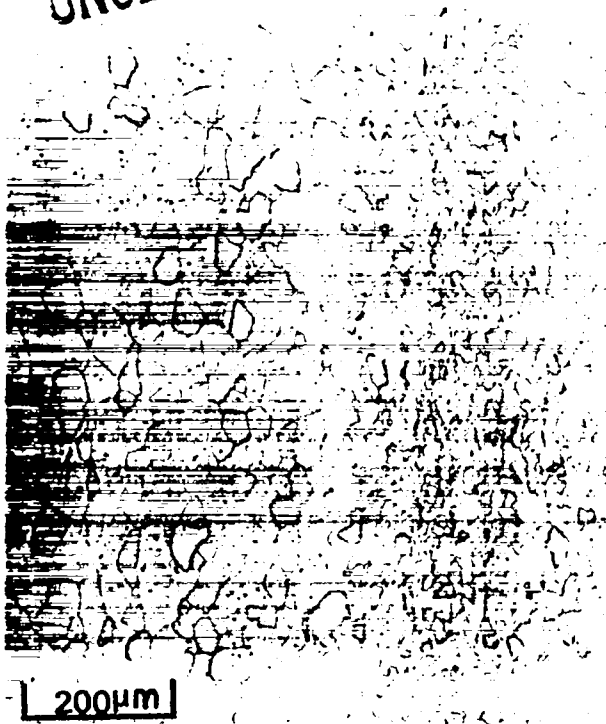

*Fig. 8.*  
Microstructure of 9.53-mm-thick tantalum plate as received from the mill.

The 6.35-mm-thick plate was cross rolled 25% using two equal passes in each direction to reach the 4.76-mm thickness necessary. As previously shown (Fig. 7) the 6.35-mm-thick material displayed a heavily banded structure as received from the mill. This resulted from the rolling procedure used by the supplier. Samples of our 25% cross rolled material were also subjected to various annealing treatments as had been done for the 50% cross rolled material. An annealing treatment of 1300°C for 30 min resulted in a hardness of DPH 73 for the 25% cross rolled material. This heat treatment was chosen despite the fact that some grain growth resulted (Fig. 10). A heat treatment of 1250°C for 30 min resulted in a finer grain size, but yielded an unacceptably high hardness of DPH 95-100.

After all the cones had been formed and appropriately annealed, one extra cone was selected for characterization. It was sectioned longitudinally and examined metallographically. The particular cone examined had been fabricated from the 25% cross rolled material and had been given the 1300°C/30 min anneal after forming. Figure 11 shows the microstructure from one area of the cone. The microstructures in other areas were all similar to that shown. Banding was observed in all sections examined, but was considerably less severe than in the starting material (Fig. 7) and even somewhat less evident than in the applicable annealing study sample (Fig. 10). The hardness of the cone at all longitudinal sections was DPH 70-75.

UNCLASSIFIED



Grain Sizes: ASTM 6,9

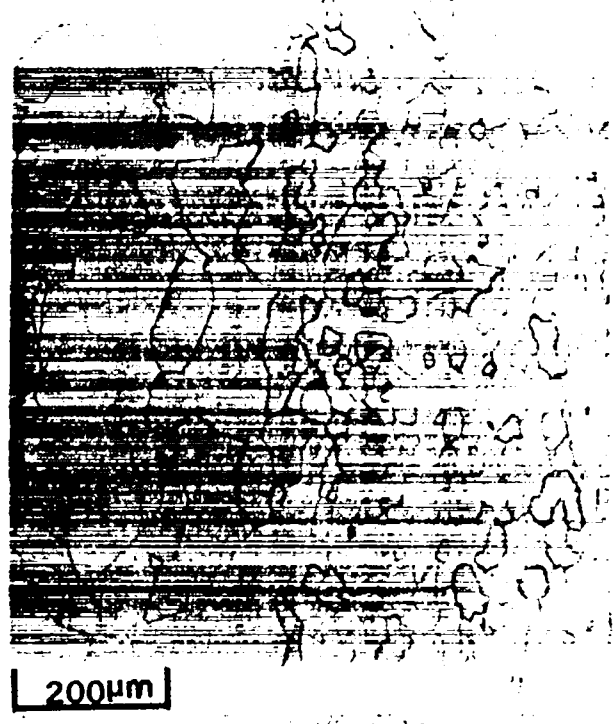

Grain Sizes: ASTM 4,7

Fig. 9.

*Microstructures of 50% cross rolled and vacuum annealed (1200°C/30 min) tantalum sheet sample. The hardness as annealed was DPH 75-78. Banded areas possessing different grain sizes were present.*

#### ACKNOWLEDGMENTS

The authors appreciate the help of E. G. Morris, J. O. Archer, and J. W. Russell, of the CMB-6 Fabrication Section in fabricating and heat treating the conical liners. We also thank T. I. Jones and C. A. Javorsky, of the CMB-6 Physical Metallurgy Section for performing the metallographic studies on this program. We additionally acknowledge the contribution of many Shops Department personnel for machining the tools and the liners. A special note of thanks to C. E. Nilsson of CMB-7 for his efforts on the tool design portion of this program.

UNCLASSIFIED

UNCLASSIFIED



Grain Sizes: ASTM 4,9

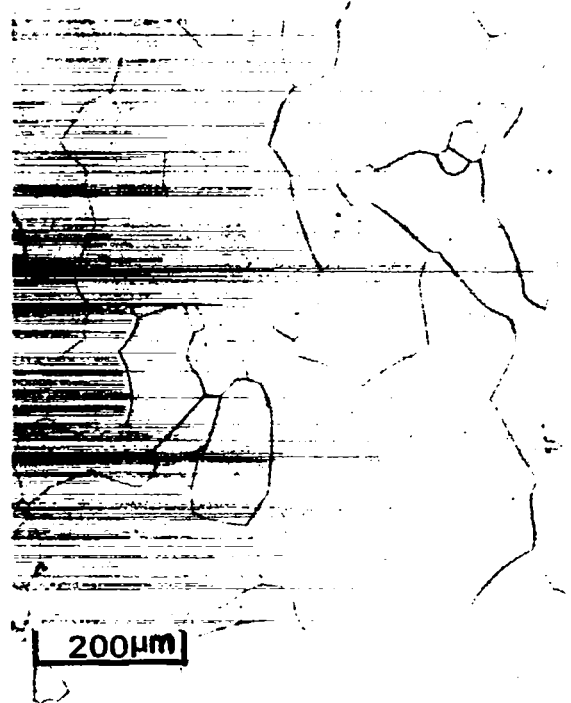

Grain Size: ASTM 2

Fig. 10.

Microstructures of 25% cross rolled and vacuum annealed (1300°C/30 min) tantalum sheet sample. The hardness as annealed was DPH 73. A banded microstructure was again evident.

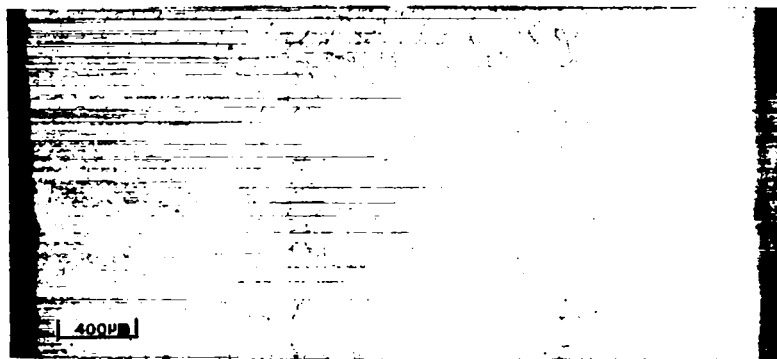

Outer surface

Center

Inner surface

Fig. 11.

Microstructure of a full wall transverse section across a 4.76-mm-thick formed and vacuum annealed (1300°C/30 min) tantalum cone. The material had been cross rolled 25% before forming. The hardness of the cone in all areas was DPH 70-75.

UNCLASSIFIED

**UNCLASSIFIED****APPENDIX A****WORK STATEMENT FOR HIGH-DENSITY SHAPED CHARGE RESEARCH**

To advance the state-of-the-art of shaped charge research, it is necessary to study jet formation from high-density liners. In this effort many metallurgical problems must be solved. This proposal is directed toward several of these problems.

The task will be divided into three phases: (1) The fabrication problems will be addressed in a cooperative effort between LASL and BRL; (2) Several liners will be evaluated at BRL, and (3) an additional design or fabrication cycle will be undertaken based on the results of phases 1 and 2.

Phase 1: Shaped charge liners 81.3 mm in diameter will be designed by BRL. These liners will be designed for two materials; pure fine-grain tantalum and tantalum-10 wt% tungsten alloy. LASL will first determine the liner wall thickness constraints (imposed by fabricability considerations) for a constant wall conical liner. Using this constraint BRL will design liners and charges with the approximate apex angle of 60°. These designs will be delivered to LASL where ten liners of each alloy will be fabricated. The material preparation and fabrication techniques will be decided upon by LASL to meet the dimensional requirements and the desire for fine grain. The material properties shall be documented and final liner dimensions confirmed by suitable quality control techniques. The liners will be shipped to BRL for ballistic testing.

Phase 2: The BRL shall inspect, assemble, and load the liners into bodies. The assembled warheads will be tested against suitable targets with flash radiographic diagnostics being employed where possible. The results will be transmitted to LASL and the extent of the Phase 3 effort will be discussed in a meeting between LASL and BRL.

Phase 3: It is intended that either additional liners of the best material will be fabricated within the funds available or that Phase 1 will be modified as the result of the testing in Phase 2.

This effort is intended to be a 1 yr, best effort undertaking with the intention of developing as much information on the design and fabrication of high-density conical shaped charge liners as is possible within the funding of \$50 000. A report detailing the efforts of these tasks will be written at the end of the program.

**APPENDIX B****TOOL DESIGN**

The design of the tools for forming these truncated cones is based on forming the required shape in a number of stages in which the volume of material converted to the conical contour during any given stage is equal to that volume removed from the sum total of the other contours. By taking this approach, one should not have any difficulties with excessive thinning of the wall in any area of the conical contour. This condition can ultimately lead to failure of the blank or produce an area in the contour that would not have sufficient material to meet finished machined dimensions. Alternatively, an overabundance of material at a specific location on the contour can cause the tools to close improperly. This can lead to buckling of the wall and contour deviations. Therefore, the calculations necessary for the tool design are quite important.

**UNCLASSIFIED**

UNCLASSIFIED

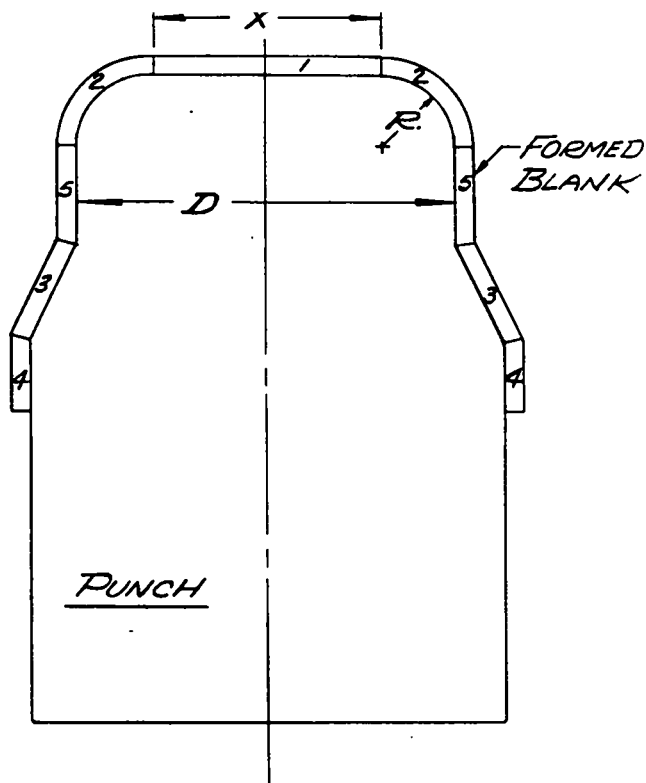

Fig. B-1.

Punch design.

Volume 1 = volume of a solid disc (cylinder)

Volume 2 = volume of one-fourth of a hollow torus

Volume 3 = volume of a hollow truncated cone

Volumes 4, 5 = volumes of hollow cylinders

The method used for the design of these tools follows:

1. Calculate the volume of the final formed shape; one must choose a blank thickness and die clearances to make this calculation.
2. Determine a "punch cylinder diameter" (D) and a punch radius (R) for the first stage punch (see Fig. B-1). For example, if a formed cone is to have an inside diameter at its base of 127 mm, a punch cylinder diameter of 114.3 mm might be a good choice for the first stage.
3. Having made these choices, calculate the volumes of the sections marked 1, 2, 3, and 4 in Fig. B-1.
4. Subtract the volume determined in Step 3 from that determined in Step 1. The resultant volume ( $V_R$ ) is the volume of Section 5 (Fig. B-1). As this represents a hollow cylinder, with a known diameter (as determined in Step 2) the height of the punch cylinder

$$h = \frac{V_R}{\frac{\pi(D_1^2 - D^2)}{4}}$$

where  $D_1 = D + (2 \times \text{blank thickness})$ .

5. This height is the only unknown once Steps 1 and 2 are completed. Therefore, once h is determined, the design of a punch is completed. This procedure can be repeated for each of the successive stages.

One problem that can occur regarding the tool design involves the initial choices made in Step 2. Generally, as one reduces the punch cylinder diameter of each successive stage, the punch

UNCLASSIFIED

**UNCLASSIFIED**

radius should also be reduced. An example of how this situation can lead to problems is given below:

**First Punch**

$$D = 73.03 \text{ mm}$$

$$R = 15.86 \text{ mm}$$

**Second Punch**

$$D = 66.68 \text{ mm}$$

$$R = 9.53 \text{ mm}$$

$$\text{From Fig. B-1: } x = D - 2R$$

$$x = 73.03 - 2(15.86) = 41.31 \text{ mm}$$

$$x = 66.68 - 2(9.53) = 47.62 \text{ mm}$$

In the case cited, the blank formed using the first stage punch would not make contact with the flat top of the second stage punch during the next forming stage because the diameter of the flat face for the second punch ( $x$ ) is larger than that of the first. The radius formed by the first stage punch into the piece would interfere with the flat portion of the second punch. The blank would therefore be resting above the flat face of the second punch and would not be properly formed. This example shows a typical situation that may result through an inauspicious choice of punch parameters. Once these are chosen and checked for inconsistencies such as that described, one may perform the calculative work to complete the design of a specific stage.

It should be noted that surface area calculations can be performed for the punch design, instead of volumetric calculations. Both types of calculations were done as a check procedure for these punches.

The die design for making the cones is quite straightforward and follows directly from the punch design.

**UNCLASSIFIED**





UNCLASSIFIED

UNCLASSIFIED